

SHARP®

MICRO COMPONENT SYSTEM

MODEL

XL-DH10NH XL-DH20NH

OPERATION MANUAL

Thank you for purchasing this SHARP product. To obtain the best performance from this product, please read this manual carefully. It will guide you in operating your SHARP product.

XL-DH10NH Micro Component System consisting of XL-DH10NH (main unit) and CP-DH10NH (speaker system).

XL-DH20NH Micro Component System consisting of XL-DH20NH (main unit) and CP-DH20NH (speaker system).

XL-DH10NH

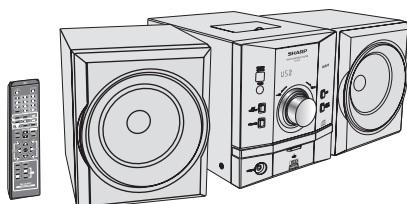

XL-DH20NH

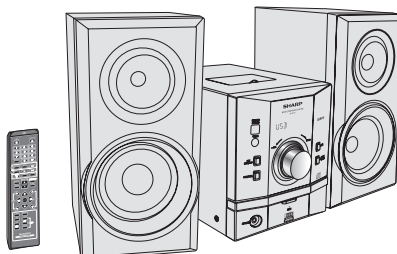

iPod is a trademark of Apple Inc., registered in the U.S. and other countries.



Special Notes

WARNINGS

- When the ON/STAND-BY button is set at STAND-BY position, mains voltage is still present inside the unit. When the ON/STAND-BY button is set at STAND-BY position, the unit may be brought into operation by the timer mode or remote control.
- This unit contains no user serviceable parts. Never remove covers unless qualified to do so. This unit contains dangerous voltages, always remove mains plug from the socket before any service operation and when not in use for a long period.
- To prevent fire or shock hazard, do not expose this appliance to dripping or splashing. No objects filled with liquids, such as vases, shall be placed on the apparatus.
- Do not turn the volume on to full at switch on. Listen to music at moderate levels. Excessive sound pressure from earphones and headphones can cause hearing loss.

Note for users in Australia:

Copyright may exist in material you wish to record. Copying or broadcasting such material without permission of the relevant licenses or owners of the copyright is prohibited by law. SHARP is not in a position to authorise the copying or broadcasting of copyright materials and nothing in this OPERATION MANUAL should be implied as giving that authority.

For other countries:

Audio-visual material may consist of copyrighted works which must not be recorded without the authority of the owner of the copyright. Please refer to the relevant laws in your country.

CAUTIONS

- This product is classified as a CLASS 1 LASER PRODUCT.
- This unit contains a low power laser device. To ensure continued safety do not remove any cover or attempt to gain access to the inside of the product. Refer all servicing to qualified personnel.
- Use of controls, adjustments or performance of procedures other than those specified herein may result in hazardous radiation exposure.

"Made for iPod" means that an electronic accessory has been designed to connect specifically to iPod and has been certified by the developer to meet Apple performance standards.

Apple is not responsible for the operation of this device or its compliance with safety and regulatory standards.







Special Note

Supply of this product does not convey a license nor imply any right to distribute content created with this product in revenue-generating broadcast systems (terrestrial, satellite, cable and/or other distribution channels), revenue-generating streaming applications (via Internet, intranets and/or other networks), other revenue-generating content distribution systems (pay-audio or audio-on-demand applications and the like) or on revenue-generating physical media (compact discs, digital versatile discs, semiconductor chips, hard drives, memory cards and the like). An independent license for such use is required. For details, please visit <http://mp3licensing.com>

MPEG Layer-3 audio coding technology licensed from Fraunhofer IIS and Thomson.

Accessories

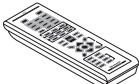
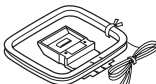
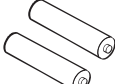
Please confirm that the following accessories are included.

 Adaptor A x 1 (FIXED TO MAIN UNIT)	 Adaptor B x 1	 Adaptor C x 1	 Adaptor D x 1	 Adaptor E x 1
 Remote control x 1	 AM loop aerial x 1	 "AAA" size battery (UM/SUM-4, R6, HP-7 or similar) x 2	 FM aerial x 1	

The illustrations printed in this operation manual are for the model XL-DH10NH.

CONTENTS

	Page	Page
General Information		Page
Precautions	3	
Controls and indicators	3 - 4	
Preparation for Use		
System connections	5	
Remote control	6	
Basic Operation		
General control	6	
Setting the clock (Remote control only)	7	
iPod		
Listening to the iPod	7 - 9	
CD or MP3/WMA disc Playback		
Listening to a CD or MP3/WMA disc	9 - 10	
Advanced CD or MP3/WMA disc playback	10 - 11	
MP3/WMA folder mode (only for MP3/WMA files)	12	
USB		
Listening to USB mass storage device/MP3 player	13 - 14	
Advanced USB playback	14	
Radio		
Listening to the radio	15	
Advanced Features		
Using the Radio Data System (RDS)	16 - 18	
Timer and sleep operation (Remote control only)	19 - 20	
Enhancing your system	21	
References		
Troubleshooting chart	21 - 22	
Maintenance	22	
Specifications	23	

Precautions

General

- Please ensure that the equipment is positioned in a well ventilated area and ensure that there is at least 10 cm (4") of free space along the sides, top and back of the equipment.

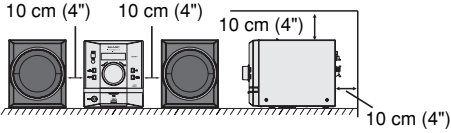

- Use the unit on a firm, level surface free from vibration.
- Keep the unit away from direct sunlight, strong magnetic fields, excessive dust, humidity and electronic/electrical equipment (home computers, facsimiles, etc.) which generate electrical noise.
- Do not place anything on top of the unit.
- Do not expose the unit to moisture, to temperatures higher than 60°C (140°F) or to extremely low temperatures.
- If your system does not work properly, disconnect the AC power lead from the wall socket. Plug the AC power lead back in, and then turn on your system.
- In case of an electrical storm, unplug the unit for safety.
- Hold the AC power plug by the head when removing it from the wall socket, as pulling the lead can damage internal wires.
- The AC power plug is used as a disconnect device and shall always remain readily operable.

- Do not remove the outer cover, as this may result in electric shock. Refer internal service to your local SHARP service facility.
- The ventilation should not be impeded by covering the ventilation openings with items, such as newspapers, tablecloths, curtains, etc.
- No naked flame sources, such as lighted candles, should be placed on the apparatus.
- Attention should be drawn to the environmental aspects of battery disposal.
- This unit should only be used within the range of 5°C - 35°C (41°F - 95°F).
- The apparatus is designed for use in moderate climates.

Warning:

The voltage used must be the same as that specified on this unit. Using this product with a higher voltage other than that which is specified is dangerous and may result in a fire or other type of accident causing damage. SHARP will not be held responsible for any damage resulting from use of this unit with a voltage other than that which is specified.

Volume control

The sound level at a given volume setting depends on speaker efficiency, location and various other factors. It is advisable to avoid exposure to high volume levels, to avoid this, do not turn the volume on to full at switch on and listen to music at moderate levels. Excessive sound pressure from earphones and headphones can cause hearing loss.

Controls and indicators

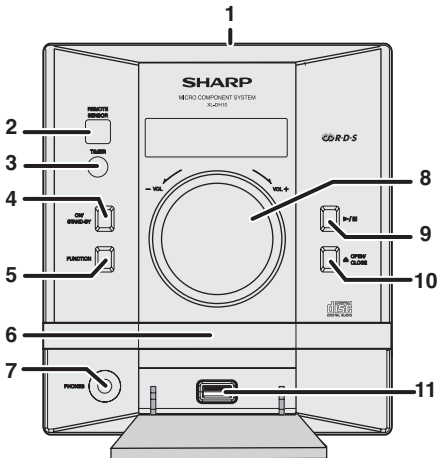

Front panel

	Page
1. iPod Docking Station	8
2. Remote Sensor	6
3. Timer Indicator	19
4. On/Stand-by Button	6, 8, 10, 19
5. Function Button	9, 10, 13
6. Disc Tray	10
7. Headphone Socket	21
8. Volume Control	6
9. Disc / USB / iPod Play or Pause or Stop Button	9, 10, 13
10. Disc Tray Open / Close Button	10
11. USB Terminal	13

Speaker system (CP-DH10NH)

1. Full Range
2. Bass Reflex Duct
3. Speaker Wire

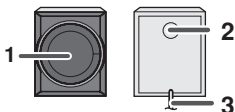

Speaker system (CP-DH20NH)

1. Tweeter
2. Woofer
3. Bass Reflex Duct
4. Speaker Wire

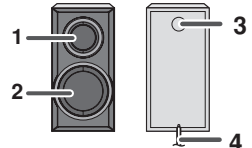

Controls and indicators (continued)

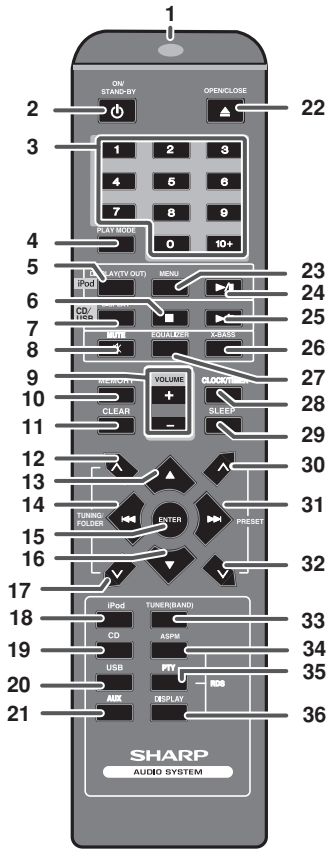

Remote control

	Page
1. Remote Control Transmitter	6
2. On / Stand-by Button	6, 7, 8, 9, 19
3. Direct Search Buttons	10
4. Play Mode Button	10, 11, 14
5. iPod Display (TV OUT) Button	5
6. CD / USB Stop Button	10, 13
7. CD / USB Display Button	12, 13
8. Mute Button	6
9. Volume Up or Down Buttons	6
10. Memory Button	7, 10, 15, 19
11. Clear Button	6, 11
12. Folder Up / Tuning Up Button	12, 13
13. iPod Cursor Up Button	12, 13, 15
14. Fast Reverse or Track Down Button	7, 9, 10, 13, 19
15. Enter Button	6, 11
16. Tuning Down Button	12, 13, 15
17. Folder Down / Tuning Down Button	5
18. iPod Button	7
19. CD Button	10
20. USB Button	13
21. AUX Button	21
22. Open / Close Button	10
23. iPod Menu Button	8, 9
24. iPod Play / Pause Button	8, 9
25. CD / USB Play / Pause Button	9, 10, 13
26. X-Bass Button	6
27. Equaliser Mode Button	6
28. Clock / Timer Button	7, 19
29. Sleep Button	20
30. Preset Up Button	15
31. Fast Forward or Track Up Button	7, 9, 10, 13, 19
32. Preset Down Button	15
33. Tuner (Band) Button	15
34. RDS ASPM Button	16
35. RDS PTY Button	16
36. RDS Display Button	16

Display

	Page
1. MP3/WMA Folder Indicator	12
2. MP3/WMA Total Indicator	12
3. Memory Indicator	11, 14
4. CD Indicator	10
5. MP3 Indicator	12
6. WMA Indicator	12
7. RDS Indicator	17
8. TA Indicator	16
9. PTYI Indicator	16
10. Extra Bass Indicator	6
11. TP Indicator	16
12. Sleep Indicator	20
13. Timer Play Indicator	20
14. Repeat Play Indicator	10
15. FM Stereo Mode Indicator	15
16. FM Stereo Receiving Indicator	15
17. Disc Play Indicator	10
18. Disc Pause Indicator	10
19. USB Indicator	14
20. Random Indicator	11

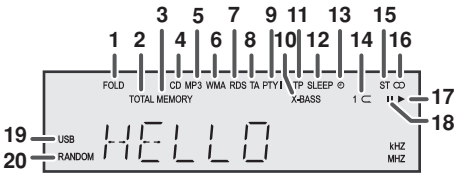

System connections

Make sure to unplug the AC power lead before making any connections.

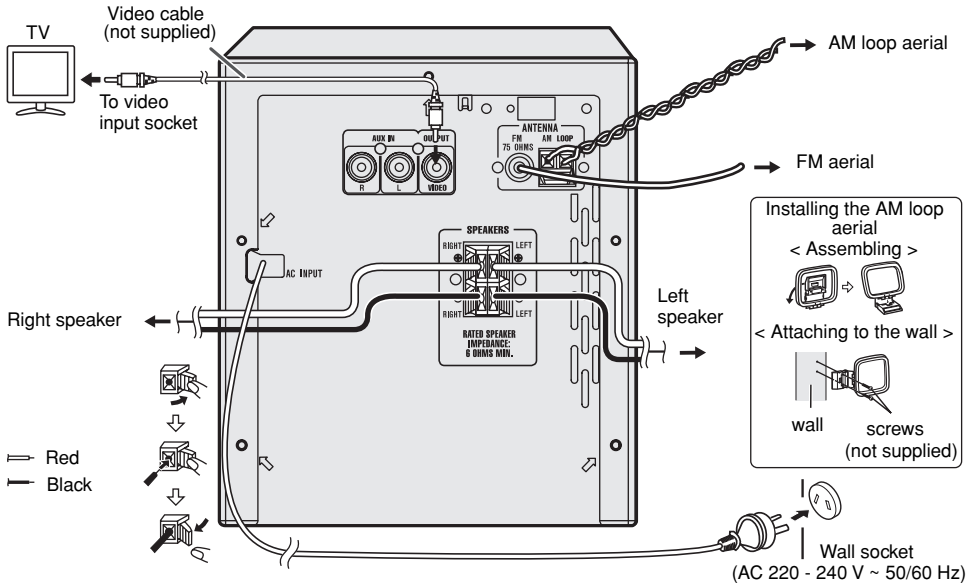

■ Aerial connection

Supplied FM aerial:
Connect the FM aerial wire to the FM 75 OHMS socket and position the FM aerial wire in the direction where the strongest signal can be received.

External FM aerial:
Use an external FM aerial (75 ohms coaxial cable) for better reception. When an external FM aerial is used, disconnect the supplied FM aerial wire.

Supplied AM loop aerial:
Connect the AM loop aerial to the AM terminal. Position the AM loop aerial for optimum reception. Place the AM loop aerial on a shelf, etc., or attach it to a stand or a wall with screws (not supplied).

Note:
Placing the aerial on the unit or near the AC power lead may cause noise pickup. Place the aerial away from the unit for better reception.

■ Speaker connection

- Connect the black wire to the minus (-) terminal, and the red wire to the plus (+) terminal.
- Use speakers with an impedance of 6 ohms or more, as lower impedance speakers can damage the unit.
- Do not mistake the right and the left channels. The right speaker is the one on the right side when you face the unit.
- Do not let the bare speaker wires touch each other.
- Do not allow any objects to fall into or to be placed in the bass reflex ducts.
- Do not stand or sit on the speakers. You may be injured.

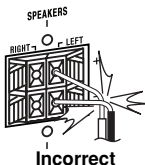

■ Connecting iPod to a TV

The iPod with photo and video can be viewed by connecting to a TV/monitor.

If the TV/monitor has a video input, connect it to the VIDEO OUT socket on the rear of the unit.

Note:
Please make sure to set iPod unit to either NTSC or PAL to match your TV signal. Please visit Apple's home page for further information.

■ AC power connection

After checking all the connections have been made correctly, plug the AC power lead of this unit into the wall socket. If you plug in the unit first, the unit will enter the stand-by mode.

Note:
Unplug the AC power lead from the wall socket if the unit will not be in use for a prolonged period of time.

Remote control

Battery installation

- 1 Open the battery cover.
- 2 Insert the batteries according to the direction indicated in the battery compartment.
When inserting or removing the batteries, push them towards the (-) battery terminals.
- 3 Close the cover.

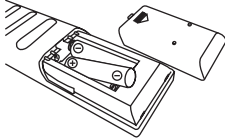

Caution:

- Replace all old batteries with new ones at the same time.
- Do not mix old and new batteries.
- Remove the batteries if the unit will not be used for a long period of time. This will prevent potential damage due to battery leakage.
- Do not use rechargeable batteries (nickel-cadmium battery, etc.).
- Installing the batteries incorrectly may cause the unit to malfunction.
- Batteries (battery pack or batteries installed) shall not be exposed to excessive heat such as sunshine, fire or the like.

Notes concerning use:

- Replace the batteries if the operating distance is reduced or if the operation becomes erratic. Purchase 2 "AAA" size batteries (UM/SUM-3, R6, HP-7 or similar).
- Periodically clean the transmitter on the remote control and the sensor on the unit with a soft cloth.
- Exposing the sensor on the unit to strong light may interfere with operation. Change the lighting or the direction of the unit if this occurs.
- Keep the remote control away from moisture, heat, shock, and vibrations.

Test of the remote control

Check the remote control after checking all the connections.

Point the remote control directly at the remote sensor on the unit. The remote control can be used within the range shown below:

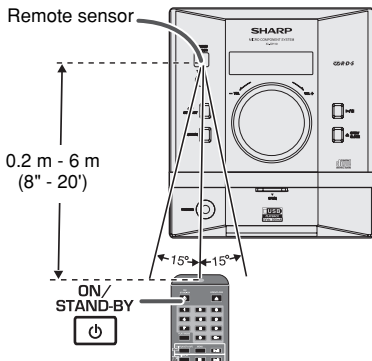

General control

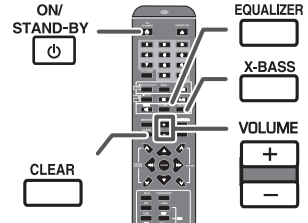
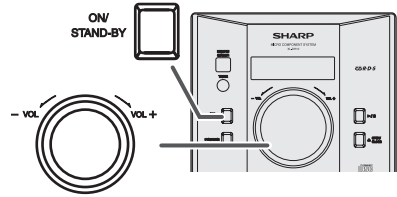

To turn the power on

Press the ON/STAND-BY button to turn the power on.

After use:

Press the ON/STAND-BY button to enter the power stand-by mode.

Volume auto set-in

- If you turn off and on the main unit with volume set to 16 or higher, the volume will start at 16.
- If you turn the unit off then on again with the volume level set to less than 15, it will turn on again at the level set.

Volume control

Turn the volume knob towards VOL +/- (on main unit) or press VOLUME +/- (on remote control) to increase or decrease the volume.

Extra bass control (X-BASS)

When the X-BASS button is pressed, the unit will enter the extra bass mode which emphasises the bass frequencies and "X-BASS" indicator will light up.

To cancel the extra bass mode, press the X-BASS button again.

Equaliser

When the EQUALIZER MODE button is pressed, the current mode setting will be displayed. To change to a different mode, press the EQUALIZER MODE button repeatedly until the desired sound mode appears.

→ FLAT	No equalisation.
↓ ROCK	For rock music.
↓ CLASSIC	For classical music.
↓ POPS	For pop music.
↓ VOCAL	Vocals are enhanced.
↓ JAZZ	For jazz.

Setting the clock (Remote control only)

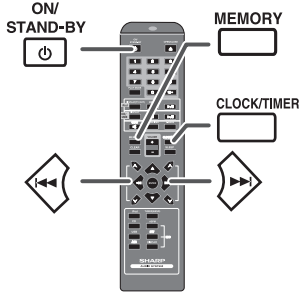

In this example, the clock is set for the 24-hour (00:00) display.

- 1 Press the ON/STAND-BY button to turn to stand-by mode.
- 2 Press and hold the CLOCK/TIMER button until "00:00" appear.



- 3 Within 10 seconds, press the ◀◀ or ▶▶ button to adjust the hour and then press the CLOCK/TIMER button. Press the ◀◀ or ▶▶ button once to advance the time by 1 hour. Hold it down to advance continuously.
- 4 Press the ◀◀ or ▶▶ button to adjust the minutes and then press the CLOCK/TIMER button. Press the ◀◀ or ▶▶ button once to advance the time by 1 minute. Hold it down to advance continuously.

To confirm the time display:

[When the unit is in the stand-by mode]
Press the CLOCK/TIMER button. The time display will appear for about 5 seconds.

[When the power is on]
Press the CLOCK/TIMER button. The time display will appear for about 5 seconds.

Note:

The "00:00" will appear when the AC power supply is restored after a power failure or unplugging the unit. Readjust the clock as follows.

To readjust the clock:

Perform "Setting the clock" from step 1.

Listening to the iPod

Supported iPod models:

- iPod nano (software 1.2 above)
- iPod mini (software 1.2 above)
- iPod (5th generation) (software 1.3 above) (Dock connector equipped Click Wheel model)
- iPod (4th generation) (software 3.0.2 above) (Dock connector equipped Click Wheel model)
- iPod nano (2nd generation) (software 1.0.0 above)
- iPod nano (3rd generation) (software 1.0.3 above)
- iPod nano (4th generation) (software 1.0.3 above)
- iPod classic (software 1.0.3 above)
- iPod touch (software 1.1 above)
- iPod touch (2nd generation) (software 2.1 above)

Caution:

Please update your iPod unit to the latest software version from Apple's homepage before using it.

Notes:

- Once the iPod is connected to the unit it will begin charging.
- The iPod unit cannot be charged whilst the main unit is in USB mode.

■ iPod adaptor connection

The marking shows which iPod fits



iPod Adaptor No.	iPod Description	Capacity
A	5G iPod (with video)	30GB
A	U2 iPod with video	30GB
A	iPod classic	80GB & 120GB
A	4G iPod & U2 iPod	20GB
A	4G iPod	40GB
A	iPod photo	40GB & 60GB
A	iPod with colour display	60GB
A	iPod Touch	8GB & 16GB
A	iPod Touch (2nd Gen.)	8GB, 16GB & 32GB
B	iPod nano	2GB & 4GB
B	iPod nano (2nd Gen.)	2GB, 4GB & 8GB
B	iPod nano (3rd Gen.)	4GB & 8GB
B	iPod nano (4th Gen.)	8GB & 16GB
C	iPod mini	4GB & 6GB
D	iPod photo & colour U2 iPod	20GB & 30GB
D	iPod with colour display	20GB, 60GB
E	5G iPod with video	60GB & 80GB
E	iPod classic	160GB

Notes:

- If you have an iPod that does not have an iPod 30 Pin connector, you can use an audio cable to connect it to the AUX IN socket.
- iPhone is not supported by this system.

Listening to the iPod (continued)

To insert iPod adaptor

- 1 Press the ON/STAND-BY button to turn the power on.
- 2 Open the iPod cover by pulling up the tip.

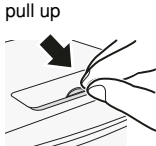

- 3 Insert the iPod adaptor into the iPod dock and connect your iPod.

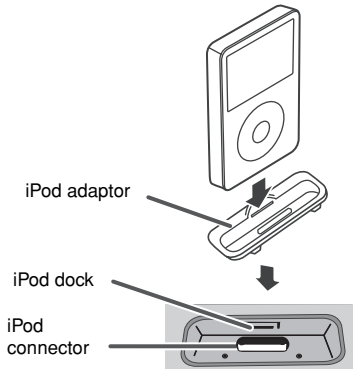
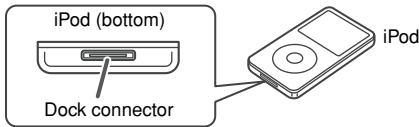

Notes:

- The unit is installed with the iPod adaptor No. A.
- Remove and insert the recommended iPod adaptor if required (refer table on page 7).

To remove iPod adaptor

Insert the tip of a screwdriver ("—" type, small) into the iPod adaptor hole as shown and lift upward to remove.

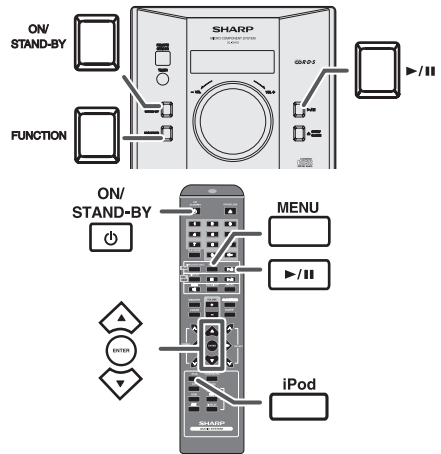
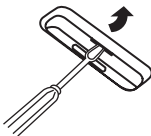

iPod playback

- 1 Press the ON/STAND-BY button to turn the power on.
- 2 Press the iPod button on the remote control or FUNCTION button on the main unit repeatedly to select iPod function.
- 3 Insert iPod unit in iPod dock of main unit.
- 4 Press the ►/|| button to start playback.

To disconnect iPod

Simply remove the iPod from the iPod dock. It is safe to do so even during playback.

Navigating the iPod menus

- 1 Press the MENU button to view the menu on iPod unit. Press it again to go back to previous menu.
- 2 Use the ▼ or ▲ button to select an item on the menu and then press ENTER button.

Note:

When navigating the iPod menus with remote control, do not operate any of the buttons on the iPod unit. The volume level is adjusted by pressing the VOL (+ or -) button on the main unit or the remote control. Adjusting the volume on the iPod unit gives no effect.

iPod operation:

The operations described below depend on the generation iPod you are using.

System on operation:

When the main unit is powered on, the iPod unit will automatically power on when docked in the unit (including TIMER function).

System off (stand-by) operation:

When the main unit is turned to stand-by mode, the docked iPod unit will automatically turn to charging mode.

Listening to the iPod (continued)

■ Watching videos on a TV connected to iPod

- 1 Press the DISPLAY (TV OUT) button for more than 2 seconds. "TV DISP" will appear on display.
- 2 Select the desired video from iPod unit to be played.
- 3 Press the ENTER button to start playback.

Notes:

- If the TV Out setting is already turned on at video menu, the video is automatically displayed on the TV screen when ENTER key is pressed.
- To return to watching video on iPod screen, press the MENU button to enter video menu. Then press the DISPLAY (TV OUT) button for more than 2 seconds until "iPodDISP" appears. Repeat steps 2 and 3.
- During iPod video playback, pressing the DISPLAY (TV OUT) button will not toggle video out display between iPod and TV.













iPod playback detection function:

Once the play button on the iPod unit is pressed, the main unit will automatically change to iPod function overriding the previous function selected.

Caution:

Unplug all accessories for the iPod before inserting it into the iPod dock.

■ Various iPod functions

Function	Main unit	Remote control	Operation
Play			Press in the pause mode.
Pause			Press in the playback mode.
Track up/down	—		Press in the playback or pause mode. If you press the button in the pause mode, press the ►/ button to start the desired track.
Fast forward/reverse	—		Press and hold down in the playback mode. Release the button to resume playback.
Display	—	DISPLAY(TV OUT) 	iPod back light ON. Press for more than 2 seconds to toggle the video out display between iPod or TV.
Repeat	—	PLAY MODE 	Press to toggle repeat mode.
Shuffle	—	PLAY MODE 	Press and hold down to toggle shuffle mode.
iPod Menu	—	MENU 	Press to view the iPod menu during iPod function.
iPod Enter	—	ENTER 	Press to confirm the selection.
iPod Cursor Up/Down	—		Press to select the iPod menu.

Listening to a CD or MP3/WMA disc

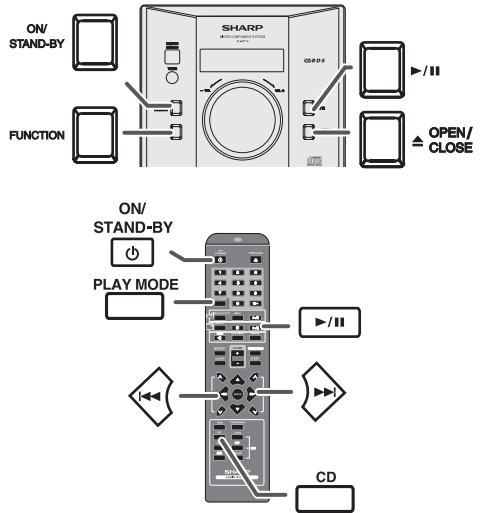

This system can play back a standard CD, CD-R/RW in the CD format and CD-R/RW with MP3 or WMA files, but cannot record on them. Some audio CD-R and CD-RW discs may not be playable due to the state of the disc or the device that was used for recording.

MP3:

MP3 is a form of compression. It is an acronym which stands for MPEG Audio Layer 3. MP3 is a type of audio code which is processed by significant compression from the original audio source with very little loss in sound quality.

- This system supports MPEG 1 Layer 3 and VBR files.
- During VBR file playback, time counter in the display may differ from its actual playback time.
- Bitrate which is supported by MP3 is 32 ~ 320 kbps.

WMA:

WMA files are Advanced System Format files that include audio files which are compressed with Windows Media Audio codec. WMA is developed by Microsoft as an audio format file for Windows Media Player.

- "MP3" and "WMA" indicator will light up after the unit reads information on an MP3 or WMA disc.
- Bitrate which is supported by WMA is 64 ~ 160 kbps.

Auto power off function:

In the stop mode of CD, MP3 or WMA operation, the main unit enters the stand-by mode after 15 minutes of inactivity.

Listening to a CD or MP3/WMA disc (continued)

Disc playback

- 1 Press the ON/STAND-BY button to turn the power on.
- 2 Press the CD button on the remote control or FUNCTION button on the main unit repeatedly to select CD function.
- 3 Press the OPEN/CLOSE button to open the disc tray.
- 4 Place the disc on the disc tray, label side up.



- 5 Press the OPEN/CLOSE button to close the disc tray.
- 6 Press the ►/|| button to start playback. After the last track is played, the unit will stop automatically.

Caution:

- Do not place two discs in one disc tray.
- Do not play discs of special shapes (heart, octagon, etc). It may cause malfunctions.
- Do not push the disc tray whilst it is moving.
- If the power fails whilst the tray is open, wait until the power is restored.
- If TV or radio interference occurs during CD operation, move the unit away from the TV or radio.
- Be sure to place 8 cm (3") disc in the middle of the disc tray.
- Due to the structure of the disc information, it takes longer to read an MP3/WMA disc than a normal CD (approximately 20 to 90 seconds).

Notes for CD or MP3/WMA disc:

- When the end of the last track is reached during fast forward, the CD operation will be stopped. When the beginning of the first track is reached during fast reverse, the unit will enter the playback mode.
- Rewritable multi-session discs with unfinished writing, can still be played.

Various disc functions

Function	Main unit	Remote control	Operation
Play			Press in the stop mode.
Stop			Press in the playback mode. Press and hold the ►/ button to stop playback.
Pause			Press in the playback mode. Press the ►/ button to resume playback from the paused point.
Track up/down	—		Press in the playback or stop mode. If you press the button in the stop mode, press the ►/ button to start the desired track.
Fast forward/reverse	—		Press and hold down in the playback mode. Release the button to resume playback.

Advanced CD or MP3/WMA disc playback

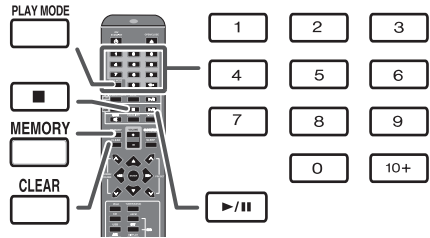

Direct track search

By using the Direct Search buttons, the desired tracks on the current disc can be played.

Use the Direct Search buttons on the remote control to select the desired track whilst playing the selected disc.

- The Direct Search buttons allow you to select up to number 9.
- When selecting number 10 or higher, use the "10+" button.

A. For example, to choose 13

- 1 Press the "10+" button once.
- 2 Press the "1" button.
- 3 Press the "3" button.

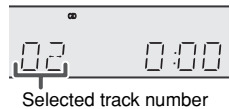

B. For example, to choose 130

- 1 Press the "10+" button twice.
- 2 Press the "1" button.
- 3 Press the "3" button.
- 4 Press the "0" button.

Notes:

- A track number higher than the number of tracks on the disc cannot be selected.
- During random play, direct search is not possible.

To stop playback:

Press and hold ►/|| button on main unit or press CD ■ button.

Repeat play

Repeat play can play one track, all tracks or a programmed sequence continuously.

To repeat one track:

Press the PLAY MODE button repeatedly until "RPT ONE" appears. Press the ►/|| button.

To repeat all tracks:

Press the PLAY MODE button repeatedly until "RPT ALL" appears. Press the ►/|| button.

To repeat all desired tracks:

Perform steps 1 - 6 in "Programmed play" section on page 11 and then press the PLAY MODE button until "RPT ALL" appears.

To cancel repeat play:

Press the PLAY MODE button again until "☞" disappears.



Advanced CD or MP3/WMA disc playback (continued)

■ Random play

The tracks on the disc can be played in random order automatically.

To random play all tracks:

Press and hold down PLAY MODE button on the remote control until "RANDOM" icon light up. Press the ►/|| button.

To cancel random play:

Press and hold the PLAY MODE button. "RANDOM" icon will disappear.

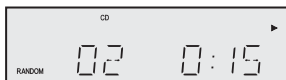

Notes:

- During random playback, repeat function is not possible.
- Playback will stop after all the tracks is played randomly.
- If you press the ►► button during random play, you can move to the track selected next by the random operation. On the other hand, the ◀◀ button does not allow you to move to the previous track.
- The beginning of the track being played will be located. In random play, the unit will select and play tracks automatically. (You cannot select the order of the tracks.)

■ Programmed play

You can choose up to 32 selections for playback in the order you like.

- 1 Whilst in the stop mode, press the MEMORY button on the remote control to enter the programming save mode.



- 2 Press the ◀◀ or ►► buttons on the remote control to select the desired track.



- 3 Press the MEMORY button to save the track number.



- 4 Repeat steps 2 - 3 for other tracks. Up to 32 tracks can be programmed. If you make a mistake, press the MEMORY button repeatedly to select the wrong track then press the CLEAR button.

- 5 Press the ►/|| button to start playback.

- 6 Press the CD ■ button. The total number in memory will appear.



To cancel the programmed play mode:

Whilst in the stop mode and the "MEMORY" indicator is lit, press the ■ button on the remote control twice. The "MEMORY" indicator will disappear and all the programmed contents will be cleared.

Adding tracks to the programme:

If a programme has been previously stored, the "MEMORY" indicator will be displayed. Press the MEMORY button repeatedly until last track appears. Then follow steps 2 - 4 to add tracks. The new tracks will be stored after the last track of the previous programme.

To check which tracks are programmed:

Whilst the unit is stopped in the programmed play mode, press the MEMORY button repeatedly.

To clear the programmed selections:

During stop mode, press the MEMORY button repeatedly to select the unwanted track. Press the CLEAR button to delete it.

Notes:

- When a disc is ejected, the programme is automatically cancelled.
- If you press the ON/STAND-BY button to enter the stand-by mode or change the function from CD to another, the programmed selections will be cleared.
- During the programme operation, random play is not possible.

MP3/WMA folder mode (only for MP3/WMA files)

To play back MP3/WMA (Windows Media Audio) file

There are many music sites on the internet that you can download MP3/WMA (Windows Media Audio) music files. Follow the instructions from the website on how to download the music files. You can then play back these downloaded music files by burning them to a CD-R/RW disc.

- Your downloaded song/files are for personal use only. Any other usage of the song without owner's permission, is against the law.

About folder playback order

If MP3/WMA files are recorded in several folders, a folder number will be set to each folder automatically.

These folders can be selected by the FOLDER (∧ or ∨) button on the remote control. If there is no supported file formats inside the selected folder, the folder is skipped and the next folder will be selected.

Example: How to set folder number if MP3/WMA format files are recorded as below figure.

- ROOT folder is set as folder 1.
- As for folders inside ROOT folder (Folder A and Folder B), the folder which is recorded earlier on the disc will be set as folder 2 and folder 3.
- As for folder inside Folder A (Folder C and Folder D), the folder which is recorded earlier on the disc will be set as folder 4 and folder 5.
- Folder E that is inside Folder D will be set as folder 6.

- The folder and file order information which is recorded on the disc depends on the writing software. There may be possibilities that this unit will playback the files not according to our expected playback order.
- For CD MP3/WMA, 255 numbers of folders and files inclusive of the folders which have non playable files can be read.

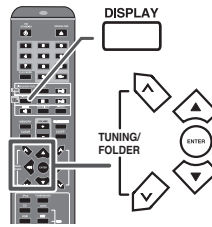
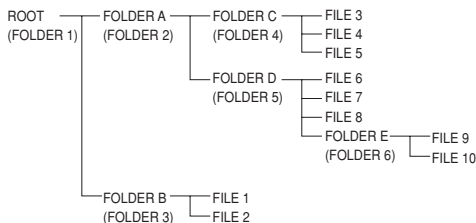

Procedure to playback MP3/WMA disc

To play back CD-R/RW.

- Press the CD button, and load an MP3/WMA disc. After disc is loaded, disc info will be displayed.



Total number of files

- Press the FOLDER (∧ or ∨) button, to select desired playback folder. (Folder mode on)



FOLDER number Total files in Folder 3

- Select desired file to be played back by pressing the ◀◀ or ▶▶ button.
- Press the ▶/|| (CD ▶/||) button. Playback will start.
 - File name, Title, Artist and Album name are displayed if they are recorded on the disc.
 - Press the FOLDER (∨ or ∧) button, and the folder can be selected even though it is in playback mode. It will continue playback mode in the 1st track of the selected folder.
 - Display content can be changed by pressing the CD DISPLAY button.

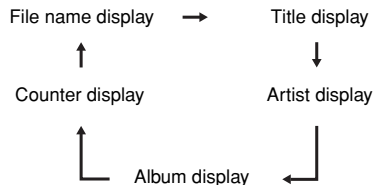

Note:

If the track is skipped during playback, it means "Copyright protected WMA file" or "Not supported playback file" is selected.

Listening to USB mass storage device/MP3 player

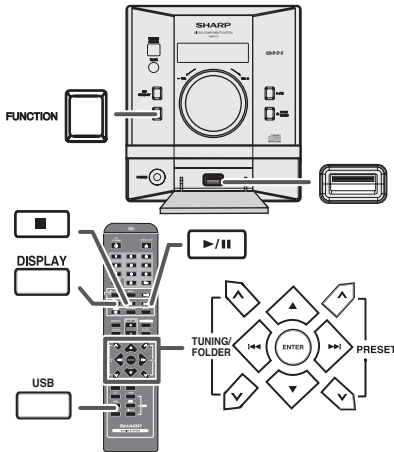

Note:

This USB mass storage device or MP3 player is not compatible with MTP and AAC file systems.

■ To play back USB/MP3 player with folder mode off

- 1 Press the USB button on the remote control or FUNCTION button on main unit repeatedly to select USB function. Connect the USB memory device that has MP3/WMA format files on the unit. When the USB memory is connected to the main unit, the device information will be displayed.

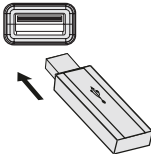

- 2 Select desired file to be played back by pressing the ◀◀ or ▶▶ button.
- 3 Press the ▶/|| (USB ▶/||) button. Playback will start.
 - Title, Artist and Album name are displayed if they are recorded in the USB memory device.
 - Display content can be changed by pressing the DISPLAY button.

Note:

To pause playback:
Press the ▶/|| (USB ▶/||) button.

Auto power off function:

In the stop mode of USB operation, the main unit enters the stand-by mode after 15 minutes of inactivity.

■ To play back USB/MP3 player with folder mode on

- 1 Press the USB button on the remote control or FUNCTION button repeatedly on main unit to select USB function. Connect the USB memory device that has MP3/WMA format files on the unit. When the USB memory is connected to the main unit, the track information will be displayed.
- 2 Press the FOLDER (∨ or ∧) button to select desired playback folder. To start playback, go to step 4. To change the playback folder, press the FOLDER (∨ or ∧) button to select another folder.
- 3 Select desired file to be played back by pressing the ◀◀ or ▶▶ button.
- 4 Press the ▶/|| (USB ▶/||) button. Playback will start.
 - Title, Artist and Album name are displayed if they are recorded in the USB memory device.
 - Display content can be changed by pressing the DISPLAY button.

■ To remove USB memory device

- 1 Press the ■ (USB ■) button to stop playback.
- 2 Disconnect USB memory device from the USB terminal.

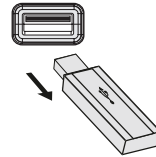

- 3 Close the terminal door.

Notes:

- SHARP will not be held liable for the loss of data whilst the USB memory device is connected to the audio system.
- Files compressed in MP3 and/or WMA format can be played back when connected to the USB terminal.
- This USB memory's format supports FAT 16 or FAT 32.
- SHARP cannot guarantee that all USB memory devices will work on this audio system.
- USB cable is not recommended for use in this audio system to connect to USB memory device. Use of the USB cable will affect the performance of this audio system.
- This USB memory cannot be operated via USB hub.
- The USB terminal in this unit is not intended for a PC connection but is used for music streaming with a USB memory device.
- External HDD-storage cannot be played back via USB terminal.
- If the data inside the USB memory is large, it may take longer time for the data to be read.

Listening to USB mass storage device/MP3 player (continued)

Notes:

- This product can play WMA and MP3 files. It will automatically detect the file type being played. If unplayable file is played on this product, the file will be automatically skipped. This will take a few seconds. If abnormal indications appear on the display due to the unspecified file, turn off the unit and then turn it on again.
- This product relates to USB mass storage devices and MP3 players. It may however face some irregularities due to various unforeseen reasons from some devices. Should this happen, turn off the unit and then turn it on again.
- The USB port is only intended for direct connection to a USB memory device without any cable.

Advanced USB playback

Repeat play

Repeat play can play all tracks sequence continuously.

To repeat one track:

Press the PLAY MODE button repeatedly until "RPT ONE" appears. Press the ►/|| (USB ►/||) button.

To repeat all tracks:

Press the PLAY MODE button repeatedly until "RPT ALL" appears. Press the ►/|| (USB ►/||) button.

To cancel repeat play:

Press the PLAY MODE button repeatedly until "NORMAL" appears and "↵" disappear.

Programmed play (Folder mode)

You can choose up to 32 selections for playback in the order you like.

- 1 Whilst in the stop mode, press the MEMORY button on the remote control to enter the programming save mode.



- 2 Press the FOLDER (✓ or ^) to select desired folder then press the ◀◀ or ▶▶ buttons to select the desired track.



Selected track number

- 3 Press the MEMORY button to save the track number.



- 4 Repeat steps 2 - 3 for other tracks. Up to 32 tracks can be programmed.
- 5 During programmed playback, press and hold ►/|| button on main unit or press the CD ■ button to stop programmed playback. The total number in memory will appear.

Advanced USB playback (continued)

Random play

The tracks can be played in random order automatically.

To random play all tracks:

Press and hold down PLAY MODE button on the remote control. Press the ►/|| (USB ►/||) button.

To cancel random play:

Press and hold the PLAY MODE button. "RANDOM" will disappear.

Notes on random play:

- During random playback, repeat function is not possible.
- Playback will stop after all the tracks is played randomly.
- If you press the ▶▶ button during random play, you can move to the track selected next by the random operation. However, the ◀◀ button does not allow you to move to the previous track. It will go to the beginning of the current track instead.
- In random play, the unit will select and play tracks automatically. (You cannot select the order of the tracks.)

Notes:

- This unit only supports "MPEG-1 Audio Layer-3" format. (Sampling Frequency is 32, 44.1, 48kHz)
- "MPEG-2 Audio Layer-3", "MPEG-2.5 Audio Layer-3" and MP1, MP2 format are not supported.
- Playback order for MP3 files may differ depending on the writing software used during file download.
- Bitrate which is supported by MP3 is 32~320 kbps, WMA is 64~160 kbps.
- For MP3/WMA files, please put ".MP3" ".WMA" extension. Files cannot be played back if there is no MP3/WMA extension.
- Playlists are not supported on this unit.
- This unit can display Folder Name or File Name up to 32 characters.
- Maximum total number of MP3/WMA files is 65280. Maximum total number of folders is 255 inclusive of root directory.
- Folders with non playable files are also counted.
- The display playback time may not be displayed correctly when playing back a variable bitrate file.
- The ID3TAG information supported are TITLE, ARTIST and ALBUM only. Title name, artist name and album name can be displayed by pressing the DISPLAY button during file playback or pause mode.
- WMA meta tag also supports title, artist and album name which are recorded in WMA files. Copyright protected WMA files cannot be played back.

Listening to the radio

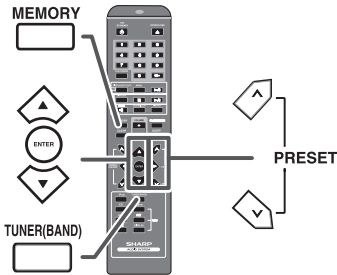
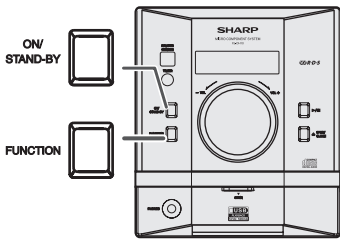

Tuning

- 1 Press the ON/STAND-BY button to turn the power on.
- 2 Press the TUNER (BAND) button repeatedly to select the desired frequency band (FM or AM).
- 3 Press the TUNING (∨ or ∧) button on the remote control to tune in to the desired station.

Manual tuning:

Press the TUNING (∨ or ∧) button repeatedly to tune in to the desired station.

Auto tuning:

When the TUNING (∨ or ∧) button is pressed for more than 0.5 seconds, scanning will start automatically and the tuner will stop at the first receivable broadcast station.

Notes:

- When radio interference occurs, auto scan tuning may stop automatically at that point.
- Auto scan tuning will skip weak signal stations.

To receive an FM stereo transmission:

- Press the TUNER (BAND) button to select stereo mode and "ST" indicator will be displayed. "∞" will appear when an FM broadcast is in stereo.
- If the FM reception is weak, press the TUNER (BAND) button to extinguish the "ST" indicator. The reception changes to monaural, and the sound becomes clearer.

Note:

This product can receive FM stereo/FM monaural and AM monaural broadcasts. AM stereo broadcasts will not be played in stereo.

Memorising a station

You can store 40 AM and FM stations in memory and recall them at the push of a button. (Preset tuning)

- 1 Perform steps 1 - 3 in "Tuning".
- 2 Press the MEMORY button.

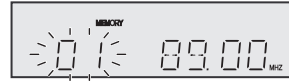

- 3 Within 5 seconds, press the ◀◀ or ▶▶ button to select the preset channel number. Store the stations in memory, in order, starting with preset channel 1.
- 4 Press the MEMORY button to store that station in memory. If the "MEMORY" and preset number indicators disappear before the station is memorised, repeat the operation from step 2.
- 5 Repeat steps 1 - 4 to set other stations, or to change a preset station. When a new station is stored in the memory, the station previously memorised for that preset channel number will be erased.

Note:

The backup function protects the memorised stations for a few hours should there be a power failure or the AC power lead become disconnected.

To recall a memorised station

Press the PRESET (∨ or ∧) button for less than 0.5 seconds to select the desired station.

To scan the preset stations

The stations saved in the memory can be scanned automatically. (Preset memory scan)

- 1 Press the PRESET (∨ or ∧) button for more than 0.5 seconds. The preset number will flash and the programmed stations will be tuned in sequentially, for 5 seconds each.
- 2 Press the PRESET (∨ or ∧) button again when the desired station is located.

To erase entire preset memory

- 1 Press and hold the CLEAR button until "CLR MEM" appears.



Using the Radio Data System (RDS)

RDS is a broadcasting service which a growing number of FM stations provide. These FM stations send additional signals along with their regular programme signals. They send their station names, and information about the type of programme such as sport, music, etc.

When tuned to an RDS station, "RDS" and the station name will be displayed.

"TP" (Traffic Programme) will appear on the display when the received broadcast carries traffic information, and "TA" (Traffic Announcement) will appear whilst a traffic information is on air.

"PTYI" (Dynamic PTY Indicator) will appear whilst the Dynamic PTY station is received.



You can control the RDS by using the buttons on the remote control only.

Information provided by RDS

Each time the RDS DISPLAY button is pressed, the display will switch as follows:

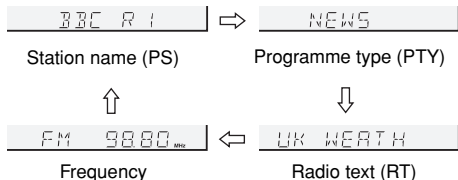
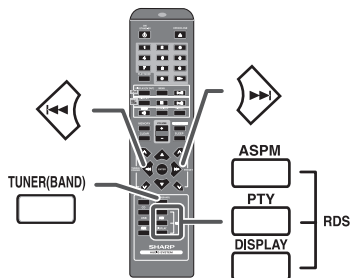

When tuning in to a station other than an RDS station or to an RDS station which sends weak signal, the display will change in the following order:

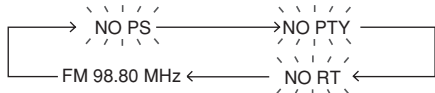

Using the Auto Station Programme Memory (ASPM)

Whilst in the ASPM operation mode, the tuner will automatically search for new RDS stations. Up to 40 stations can be stored.

If you have already stored some stations in memory, the number of new stations you can store will be less.

- 1 Press the TUNER button on the remote control or FUNCTION button repeatedly on the main unit to select TUNER function.
- 2 Press and hold down the RDS ASPM button on the remote control for at least 3 seconds.
 - 1 After "ASPM" has flashed for about 4 seconds, scanning will start (87.50 - 108.00 MHz).



- 2 When an RDS station is found, "RDS" will appear for a short time and the station will be stored in memory.

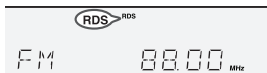

- 3 After scanning, the number of stations stored in memory will be displayed for 4 seconds, and then "END" will appear for 4 seconds.



To stop the ASPM operation before it is complete:

Press the RDS ASPM button whilst it is scanning for stations. The stations which are already stored in memory will be kept there.

Notes:

- If the same station is broadcasting on different frequencies, the strongest frequency will be stored in memory.
- Any station which has the same frequency as the one stored in memory will not be stored.
- If 40 stations have already been stored in memory, the scan will be aborted. If you want to redo the ASPM operation, erase the preset memory.
- If no station have been stored in memory, "00 MEM" and "END" will appear for about 4 seconds.
- If the RDS signals are very weak, station names may not be stored in memory.
- The same station name can be stored in different channels.
- In a certain area or during certain time periods, the station names may temporarily be different.

Using the Radio Data System (RDS) (continued)

■ Notes for RDS operation

If any of the following events occur, it does not mean that the unit is faulty:

- “PS”, “NO PS” and a station name appear alternately, and the unit does not operate properly.
- If a particular station is not broadcasting properly or a station is conducting tests, the RDS reception function may not work properly.
- When you receive an RDS station whose signal is too weak, information like the station name may not be displayed.
- “NO PS”, “NO PTY” or “NO RT” will flash for about 5 seconds, and then the frequency will be displayed.

Notes for radio text:

- The first 8 characters of the radio text will appear for 4 seconds and then they will scroll across the display.
- If you tune in to an RDS station which is not broadcasting any radio text, “NO RT” will be displayed when you switch to the radio text position.
- Whilst radio text data is received or when the text contents change, “RT” will be displayed.

■ To recall stations in memory

To specify programmed types and select stations (PTY search):

You can search a station by specifying the programme type (news, sports, traffic programme, etc. ... see page 18) from the stations in memory.

- 1 Press the TUNER (BAND) button on the remote control or FUNCTION button on the main unit repeatedly to select TUNER function.
- 2 Press the RDS PTY button on the remote control.

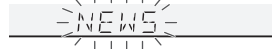

Selected PTY code (blinking) will appear for about 6 seconds.

- 3 Within 6 seconds, press the ◀◀ or ▶▶ button to select the PTY code.



Each time the button is pressed, the PTY code will appear.

- 4 Whilst the selected PTY code is displayed (within 6 seconds), press the RDS PTY button again.

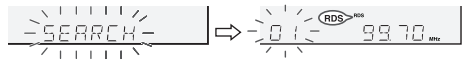

- The unit searches the all preset stations and stops when it finds a station of the selected category then tunes into the stations. The RDS indicator lights up.
- If no programme is found in the all preset stations, “NONE” appear on the display and returns to the previous station.

Notes:

- If the display has stopped flashing, start again from step 2. If the unit finds a desired programme type, the corresponding channel number will lit for about 4 seconds, and then the station name will remain it.
- If you want to listen to the same programme type of another station, press the RDS PTY button and start again from step 2. The unit will look for the next station.

Using the Radio Data System (RDS) (continued)

Descriptions of the PTY (Programme Type) codes, TP (Traffic Programme) and TA (Traffic Announcement)

You can search for and receive the following PTY, TP and TA signals.

NEWS	Short accounts of facts, events and publicly expressed views, reportage and actuality.
AFFAIRS	Topical programme expanding or enlarging upon the news, generally in different presentation style or concept, including debate, or analysis.
INFO	Programmes whose purpose is to impart advice in the widest sense.
SPORT	Programme concerned with any aspect of sport.
EDUCATE	Programme intended primarily to educate, of which the formal element is fundamental.
DRAMA	All radio plays and serials.
CULTURE	Programmes concerned with any aspect of national or regional culture, including language, theatre, etc.
SCIENCE	Programmes about the natural sciences and technology.
VARIED	Used for mainly speech-based programmes usually of light-entertainment nature, not covered by other categories. Examples include: quizzes, panel games, personality interviews.
POP M	Commercial music, which would generally be considered to be of current popular appeal, often featuring in current or recent record sales charts.
ROCK M	Contemporary modern music, usually written and performed by young musicians.
EASY M	Current contemporary music considered to be "easy-listening", as opposed to Pop, Rock or Classical, or one of the specialised music styles, Jazz, Folk or Country. Music in this category is often but not always, vocal, and usually of short duration.
LIGHT M	Classical music for general, rather than specialist appreciation. Examples of music in this category are instrumental music, and vocal or choral works.
CLASSICS	Performances of major orchestral works, symphonies, chamber music, etc., and including Grand Opera.
OTHER M	Musical styles not fitting into any of the other categories. Particularly used for specialist music of which Rhythm & Blues and Reggae are examples.
WEATHER	Weather reports and forecasts and meteorological information.
FINANCE	Stock Market reports, commerce, trading, etc.

CHILDREN	For programmes targeted at a young audience, primarily for entertainment and interest, rather than where the objective is to educate.
SOCIAL	Programmes about people and things that influence them individually or in groups. Includes: sociology, history, geography, psychology and society.
RELIGION	Any aspect of beliefs and faiths, involving a God or Gods, the nature of existence and ethics.
PHONE IN	Involving members of the public expressing their views either by phone or at a public forum.
TRAVEL	Features and programmes concerned with travel to near and far destinations, package tours and travel ideas and opportunities. Not for use for announcements about problems, delays, or roadworks affecting immediate travel where TP/TA should be used.
LEISURE	Programmes concerned with recreational activities in which the listener might participate. Examples include, Gardening, Fishing, Antique collecting, Cooking, Food & Wine, etc.
JAZZ	Polyphonic, syncopated music characterised by improvisation.
COUNTRY	Songs which originate from, or continue the musical tradition of the American Southern States. Characterised by a straightforward melody and narrative story line.
NATION M	Current Popular Music of the Nation or Region in that country's language, as opposed to International "Pop" which is usually US or UK inspired and in English.
OLDIES	Music from the so-called "golden age" of popular music.
FOLK M	Music which has its roots in the musical culture of a particular nation, usually played on acoustic instruments. The narrative or story may be based on historical events or people.
DOCUMENT	Programme concerned with factual matters, presented in an investigative style.
TEST	Broadcast when testing emergency broadcast equipment or receivers.
ALARM !	Emergency announcement made under exceptional circumstances to give warning of events causing danger of a general nature.
NONE	No programme type (receive only).

Timer and sleep operation (Remote control only)

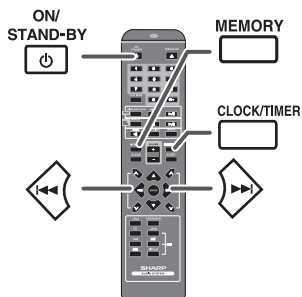

Timer playback:

The unit turns on and plays the desired source (CD, TUNER, USB, iPod) at a preset time.

■ Timer playback

Before setting timer:

- 1 Check that the clock is set to the correct time (refer to page 7).
If it is not set, you cannot use the timer function.
- 2 For timer playback, load the disc to be played back.



- 1 Press the ON/STAND-BY button to turn the power on.
- 2 Press the CLOCK/TIMER button for about 2 seconds.

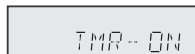

- 3 Within 10 seconds, press the CLOCK/TIMER button.
- 4 Press the ◀◀ or ▶▶ button to set hour then press the CLOCK/TIMER button.

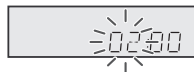

- 5 Press the ◀◀ or ▶▶ button to set minute and then press the CLOCK/TIMER button.

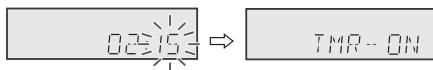

- 6 Switch input with the ◀◀ or ▶▶ button to select "TMR-OFF" and then press the CLOCK/TIMER button.

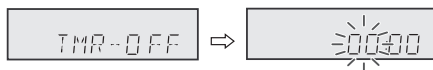

- 7 Press the ◀◀ or ▶▶ button to set hour and then press the CLOCK/TIMER button.

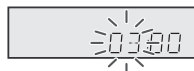

- 8 Press the ◀◀ or ▶▶ button to set minute and then press the CLOCK/TIMER button.



- 9 To select the timer playback source, switch input with ◀◀ or ▶▶ button to select "SOURCE", then press the CLOCK/TIMER button.



Timer and sleep operation (Remote control only) (continued)

- 10** Press the ◀ or ▶ button to select wake up source (CD, USB, Tuner, iPod) then press the CLOCK/TIMER button to confirm.

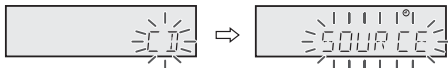

- 11** If "TUNER" is selected, press the CLOCK/TIMER button to enter the preset selection mode.

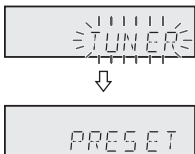

- 12** To select a preset channel number, press the ◀ or ▶ button and then press the CLOCK/TIMER button.

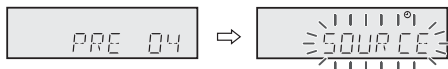

- 13** The "o" indicator lights up and the unit is ready for timer playback.

- 14** Press the ON/STAND-BY button to enter the power stand-by mode. Press the CLOCK/TIMER button to confirm the timer setting.

- 15** When the preset time is reached, playback will start. "o" indicator will blink to show timer playback. The volume will increase gradually until it reaches the last volume level.

- 16** When the timer end time is reached, the system will enter the power stand-by mode automatically.

Checking the timer setting:

- 1** Press the CLOCK/TIMER button repeatedly to view as follow:



Cancelling the timer setting:

Press the SLEEP button for 2 seconds. The "o" indicator disappears and the display show "TMR-OFF".

Reusing the memorised timer setting:

The timer setting will be memorised once it is entered. To reuse the same setting, press the SLEEP button for 2 seconds.

The "o" indicator light up and the display show "TMR-ON".

Notes:

- After selecting the playback source, when press the CLOCK/TIMER button to confirm, "SOURCE" will appear and blink for 2 seconds, then change to last function.
- When the preset time is reached, playback will start at current setting if no selected playback source is made.
- The volume cannot be preset during timer setting.

Sleep operation

The radio, compact disc and USB can all be turned off automatically.

- 1 Play back the desired sound source.
- 2 Press the SLEEP button.
- 3 Within 10 seconds, press the SLEEP button repeatedly to select the time.
10 → 20 → 30 → ... → 80 → 90
- 4 "SLEEP" will appear.
- 5 The unit will enter the power stand-by mode automatically after the preset time has elapsed.

To confirm the remaining sleep time:

- 1 Whilst "SLEEP" is indicated, press the SLEEP button. The remaining time is displayed for about 10 seconds.

To cancel the sleep operation:

Press the ON/STAND-BY button whilst "SLEEP" is indicated. To cancel the sleep operation without setting the unit to the stand-by mode, proceed as follows.

- 1 Whilst "SLEEP" is indicated, press the SLEEP button.
- 2 Within 10 seconds, press the SLEEP button repeatedly to select "SLEEP 00".

To use timer and sleep operation together

Sleep and timer playback:

For example, you can fall asleep listening to the radio and wake up to CD in the next morning.

- 1 Set the sleep time (see above, steps 1 - 5).
- 2 Whilst the sleep timer is set, set the timer playback (steps 2 - 10, pages 19 - 20).

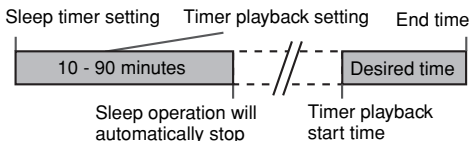

Enhancing your system

The connection lead is not included. Purchase a commercially available lead as shown below.

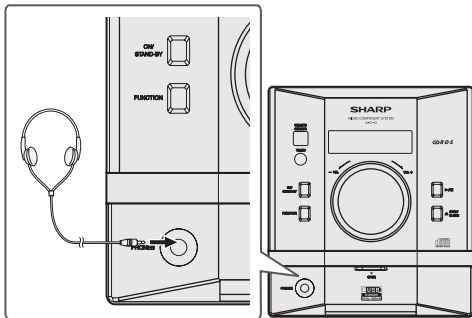

■ Listening to the playback sounds of portable audio player, etc.

- 1 Use a connection lead to connect the portable audio player etc. to the AUX IN socket. When using video equipment, connect the audio output to this unit and the video output to a television.
- 2 Press the ON/STAND-BY button to turn the power on.
- 3 Press the AUX IN button on the remote control or FUNCTION button repeatedly on main unit to select AUX IN function.
- 4 Play the connected equipment. If volume level of the connected device is too high, sound distortion may occur. Should this happen, lower the volume of the connected device. If volume level is too low, increase the volume of the connected device.

Note:

To prevent noise interference, place the unit away from the television.

■ Headphones

- Do not turn the volume on to full at switch on and listen to music at moderate levels. Excessive sound pressure from earphones and headphones can cause hearing loss.
- Before plugging in or unplugging the headphones, reduce the volume.
- Be sure your headphones have a 3.5 mm (1/8") diameter plug and impedance between 16 and 50 ohms. The recommended impedance is 32 ohms.
- Plugging in the headphones disconnects the speakers automatically. Adjust the volume using the VOLUME control.

Troubleshooting chart

Many potential problems can be resolved by the owner without calling a service technician.

If something is wrong with this product, check the following before calling your authorised SHARP dealer or service centre.

■ General

Symptom	Possible cause
● The clock is not set to the correct time.	● Did a power failure occur? Reset the clock. (Refer page 7)
● When a button is pressed, the unit does not respond.	<ul style="list-style-type: none"> ● Set the unit to the power stand-by mode and then turn it back on. ● If the unit still malfunctions, reset it. (Refer page 22)
● No sound is heard.	<ul style="list-style-type: none"> ● Is the volume level set to "0"? ● Are the headphones connected? ● Are the speaker wires disconnected?

■ CD player

Symptom	Possible cause
<ul style="list-style-type: none"> ● Playback does not start. ● Playback stops in the middle or is not performed properly. 	<ul style="list-style-type: none"> ● Is the disc loaded upside down? ● Does the disc satisfy the standards? ● Is the disc distorted or scratched?
● Playback sounds are skipped, or stopped in the middle of a track.	<ul style="list-style-type: none"> ● Is the unit located near excessive vibrations? ● Is the disc very dirty? ● Has condensation formed inside the unit?

■ Remote control

Symptom	Possible cause
● The remote control does not operate.	<ul style="list-style-type: none"> ● Is the AC power lead of the unit plugged in? ● Is the battery polarity correct? ● Are the batteries dead? ● Is the distance or angle incorrect? ● Does the remote control sensor receive strong light?

■ Tuner

Symptom	Possible cause
● The radio makes unusual noises continuously.	<ul style="list-style-type: none"> ● Is the unit placed near the TV or computer? ● Is the FM aerial or AM loop aerial placed properly? Move the aerial away from the AC power lead if it is located nearby.

Troubleshooting chart (continued)

■ USB

Symptom	Possible cause
<ul style="list-style-type: none"> ● Device cannot be detected. 	<ul style="list-style-type: none"> ● Is there any MP3/WMA file available? ● Is the device properly connected? ● Is it an MTP device? ● Does the device contain AAC file only?
<ul style="list-style-type: none"> ● Playback does not start. 	<ul style="list-style-type: none"> ● Is it a copyright protected WMA file? ● Is it a false MP3 file?
<ul style="list-style-type: none"> ● Wrong time display. ● Wrong file name display. 	<ul style="list-style-type: none"> ● Is Variable Bitrate file being played back? ● Is the File Name written in Chinese or Japanese characters?
<ul style="list-style-type: none"> ● Recording cannot start. 	<ul style="list-style-type: none"> ● Is the USB device in write protect mode? ● Is it a CD-WMA disc? ● Is the device's memory already full?

■ iPod

Symptom	Possible cause
<ul style="list-style-type: none"> ● No sound is produced. No image appears on the TV/monitor. 	<ul style="list-style-type: none"> ● The iPod is not playing. ● The iPod is not properly connected to the unit. ● Is the AC power lead of the unit plugged in? ● The video cable is not properly connected. ● The TV/monitor's input selection is not properly set.
<ul style="list-style-type: none"> ● iPod will not charge. 	<ul style="list-style-type: none"> ● Wrong iPod adaptor is used. ● The iPod is not making full contact with the iPod connector. ● The main unit is in stand-by mode. ● Using 3rd generation iPod.

■ Condensation

Sudden temperature changes, storage or operation in an extremely humid environment may cause condensation inside the cabinet (CD pickup, etc.) or on the transmitter on the remote control. Condensation can cause the unit to malfunction. If this happens, leave the power on with no disc in the unit until normal playback is possible (about 1 hour). Wipe off any condensation on the transmitter with a soft cloth before operating the unit.

■ If problem occurs

When this product is subjected to strong external interference (mechanical shock, excessive static electricity, abnormal supply voltage due to lightning, etc.) or if it is operated incorrectly, it may malfunction.

If such a problem occurs, do the following:

- 1 Set the unit to the stand-by mode and turn the power on again.
- 2 If the unit is not restored in the previous operation, unplug and plug in the unit again, and then turn the power on.

Note:

If neither operation above restores the unit, clear all the memory by resetting it.

■ Factory reset, clearing all memory

- 1 Press the ON/STAND-BY button to enter the power stand-by mode.
- 2 Whilst pressing down the OPEN/CLOSE button, press the ON/STAND-BY button until "RESET" appears.



Caution:

This operation will erase all data stored in memory including clock, timer settings, tuner preset, and CD programme.

■ Before transporting the unit

Remove all CDs from the unit. Make sure there is no CD in the disc tray. Then, set the unit to the power stand-by mode. Carrying the unit with discs left inside can damage the unit.

■ Care of compact discs

Compact discs are fairly resistant to damage, however mistracking can occur due to an accumulation of dirt on the disc surface. Follow the guidelines below for maximum enjoyment from your CD collection and player.

- Do not write on either side of the disc, particularly the non-label side from which signals are read. Do not mark this surface.
- Keep your discs away from direct sunlight, heat, and excessive moisture.
- Always hold the CDs by the edges. Fingerprints, dirt, or water on the CDs can cause noise or mistracking. If a CD is dirty or does not play properly, clean it with a soft, dry cloth, wiping straight out from the centre, along the radius.

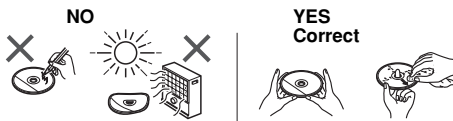

Maintenance

■ Cleaning the cabinet

Periodically wipe the cabinet with a soft cloth and a diluted soap solution, then with a dry cloth.

Caution:

- Do not use chemicals for cleaning (petrol, paint thinner, etc.). It may damage the cabinet.
- Do not apply oil to the inside of the unit. It may cause malfunctions.

Specifications

As part of our policy of continuous improvement, SHARP reserves the right to make design and specification changes for product improvement without prior notice. The performance specification figures indicated are nominal values of production units. There may be some deviations from these values in individual units.

General

Power source	AC 220 - 240 V ~ 50/60 Hz
Power consumption XL-DH10NH	Power on: 25 W Power stand-by: 0.6 W (*)
Power consumption XL-DH20NH	Power on: 45 W Power stand-by: 0.6 W (*)
Dimensions	Width: 155 mm (6-3/32") Height: 178 mm (7-1/64") Depth: 243 mm (9-9/16")
Weight XL-DH10NH	2.12 kg (4.67 lbs.)
Weight XL-DH20NH	2.12 kg (4.67 lbs.)

(*) This power consumption value is obtained when the main unit is in stand-by mode without iPod charging.

Amplifier

Output power XL-DH10NH	MPO: 24 W (12 W + 12 W) (10% T.H.D.) RMS: 24 W (12 W + 12 W) (10% T.H.D.)
Output power XL-DH20NH	MPO: 50 W (25 W + 25 W) (10% T.H.D.) RMS: 50 W (25 W + 25 W) (10% T.H.D.)
Output terminals	Speakers: 6 ohms Headphones: 16 - 50 ohms (recommended: 32 ohms)
Input terminals	AUX IN (Analogue input): 500 mV/47 k ohms

CD player

Type	Single disc multi-play compact disc player
Signal readout	Non-contact, 3-beam semiconductor laser pickup
D/A converter	Multi bit D/A converter
Frequency response	20 - 20,000 Hz
Dynamic range	90 dB (1 kHz)

USB

USB host interface	<ul style="list-style-type: none"> Complies with USB 1.1 (Full Speed)/ 2.0 Mass Storage Class. Support Bulk only and CBI protocol.
Support file	<ul style="list-style-type: none"> MPEG 1 Layer 3 WMA (Non DRM)
Bitrate support	<ul style="list-style-type: none"> MP3 (32 ~ 320 kbps) WMA (64 ~ 160 kbps)
Other	<ul style="list-style-type: none"> Maximum total number of MP3/WMA files is 65280. Maximum total number of folders is 255 INCLUSIVE of root directory. The ID3TAG information supported are TITLE, ARTIST and ALBUM only. Supports ID3TAG version 1 and version 2.
File system support	<ul style="list-style-type: none"> Support USB devices with Microsoft Windows/DOS/FAT 12/ FAT 16/ FAT 32. 2 kbyte block length for sector.

Tuner

Frequency range	FM: 87.5 - 108 MHz AM: 522 - 1,620 kHz
------------------------	---

Speaker (CP-DH10NH)

Type	1-way type speaker system 10 cm (4") Full range
Maximum input power	24 W
Rated input power	12 W
Impedance	6 ohms
Dimensions	Width: 147 mm (5-51/64") Height: 174 mm (6-13/16") Depth: 171.5 mm (6-49/64")
Weight	1.53 kg (3.37 lbs.)/each

Speaker (CP-DH20NH)

Type	2-way 2-speaker system 5 cm (2") tweeter 10 cm (4") woofer
Maximum input power	50 W
Rated input power	25 W
Impedance	6 ohms
Dimensions	Width: 132 mm (5-13/64") Height: 260 mm (10-15/64") Depth: 171.5 mm (6-49/64")
Weight	1.98 kg (4.36 lbs.)/each

SHARP

FOR LOCATION ENQUIRIES WITHIN

AUSTRALIA

REGARDING YOUR LOCAL
SHARP APPROVED SERVICE CENTRE
VISIT OUR WEBSITE AT

www.sharp.net.au

OR CALL SHARP CUSTOMER CARE

1300 135 022

(LOCAL CALL COSTS APPLY WITHIN AUSTRALIA)

SHARP CORPORATION OF AUSTRALIA PTY LTD

SHARP

FOR LOCATION ENQUIRIES WITHIN

NEW ZEALAND

REGARDING YOUR LOCAL
SHARP APPROVED SERVICE CENTRE
VISIT OUR WEBSITE AT

www.sharp.net.nz

CONTACT YOUR SELLING DEALER/RETAILER
OR CALL

SHARP CUSTOMER SERVICES

TELEPHONE: 09 573 0111

FACSIMILE: 09 573 0113

SHARP CORPORATION OF NEW ZEALAND LIMITED

SPform019(JUNE 2004)

SHARP

WARRANTY

Consumer Electronic Products

Congratulations on Your Purchase!

This Sharp product is warranted against faults in materials and manufacture for a period of twelve(12) months from the date of original purchase.

If service is required during the warranty period, please contact your nearest Sharp Approved Service Centre. These repairs would be carried out at no charge to the owner, subject to the conditions specified herein.

The owner is responsible for any transportation and insurance costs if the product has to be returned for repair.

This warranty does not extend to accessories or defects or injuries caused by or resulting from causes not attributable to faulty parts or the manufacture of the product, including but not limited to, defect or injury caused by or resulting from misuse, abuse, neglect, accidental damage, improper voltage, liquid spillage, vermin infestation, software, or any alterations made to the product which are not authorised by Sharp.

Please retain your sales documentation, as this should be produced to validate a warranty claim.

This warranty is in addition to and in no way limits, varies or excludes any express and implied rights and remedies under any relevant legislation in the country of sale.

IMPORTANT

DO NOT RETURN THIS DOCUMENT TO SHARP

For your reference, please enter the particulars of your purchase below and retain, with your purchase documentation.

Model No. _____ Date of Purchase _____

Serial No. _____ Retailer _____

SHARP
SHARP CORPORATION OF AUSTRALIA PTY LIMITED
ABN 40 003 039 436
1 Hummwood Drive
Huntingwood, NSW 2148
SHARP CORPORATION OF NEW ZEALAND LIMITED
551 Hinga Johnson Drive
Ponsonby, Auckland
SPform019(JUNE 2004)

IMPORTANT NOTICE: This warranty applies only to products sold in Australia & New Zealand

SHARP®

SHARP CORPORATION



92L410CM904021

09J R MW (1)